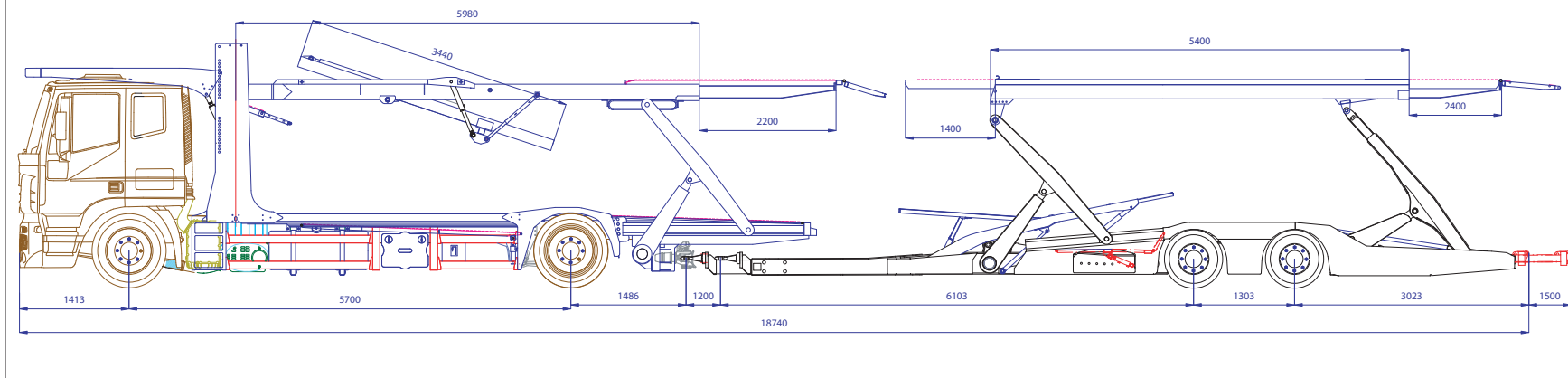

serie **5**

vers.STD.

DATI TECNICI
MOTRICE

Trasporto vetture a due piani, sistema di sollevamento anteriore con montanti a vite, sistema di sollevamento posteriore a forbice
 Campana e gancio traino
 Pensilina sopra cabina sollevabile
 Piano superiore con pianalino negativo con doppia traslazione
 Prolunga idraulica superiore posteriore mm.2200
 Buche idrauliche tra assi e sulla coda manuali

RIMORCHIO

PTT 16 -17-18-18,6ton., sistema di sollevamento anteriore e posteriore a forbice
 Assali a ruote doppie e sistema frenante EBS
 Timone idraulico con cilindro autobloccante corsa utile mm.1200
 Sospensioni pneumatiche con comando in cabina
 Prolunga idraulica inferiore posteriore corsa utile mm.1500
 Pianalino idraulico a 3 funzioni con buche idrauliche sottostanti
 Pianale superiore con pannelli modulari o tappi manuali
 Prolunga idraulica superiore anteriore corsa utile mm.1400
 Prolunga idraulica superiore posteriore corsa utile mm.2400
 Buca manuale coda
 Accessori di serie

TECHNICAL DATA
TRUCK STRUCTURE

Car transporter with two platforms, pillars front lifting system and rear with scissors
 Hooking and towing system
 Top cabin ramp hydraulically lifting
 Top platform with double translation negative ramp
 Hydraulic rear extension of 2200 mm. length
 Hydraulic holes between the axels and on the tail manual

TRAILER

GVW 16-17-18-18,6 tons, front and back scissors lifting system
 Double wheel axels and braking system EBS
 Hydraulic draw bar with auto blocking cylinder system of 1200 mm. length
 Pneumatic suspension with in cabin command
 Hydraulic rear extension with useful length of 1500 mm.
 Hydraulic ramp with 3 functions with hydraulic holes underneath
 Top platform with modular panels or manual taps
 Top front hydraulic extension with useful length of 1400 mm.
 Top rear hydraulic extension with useful length of 2400 mm.
 Manual holes on the tail
 Series accessories