

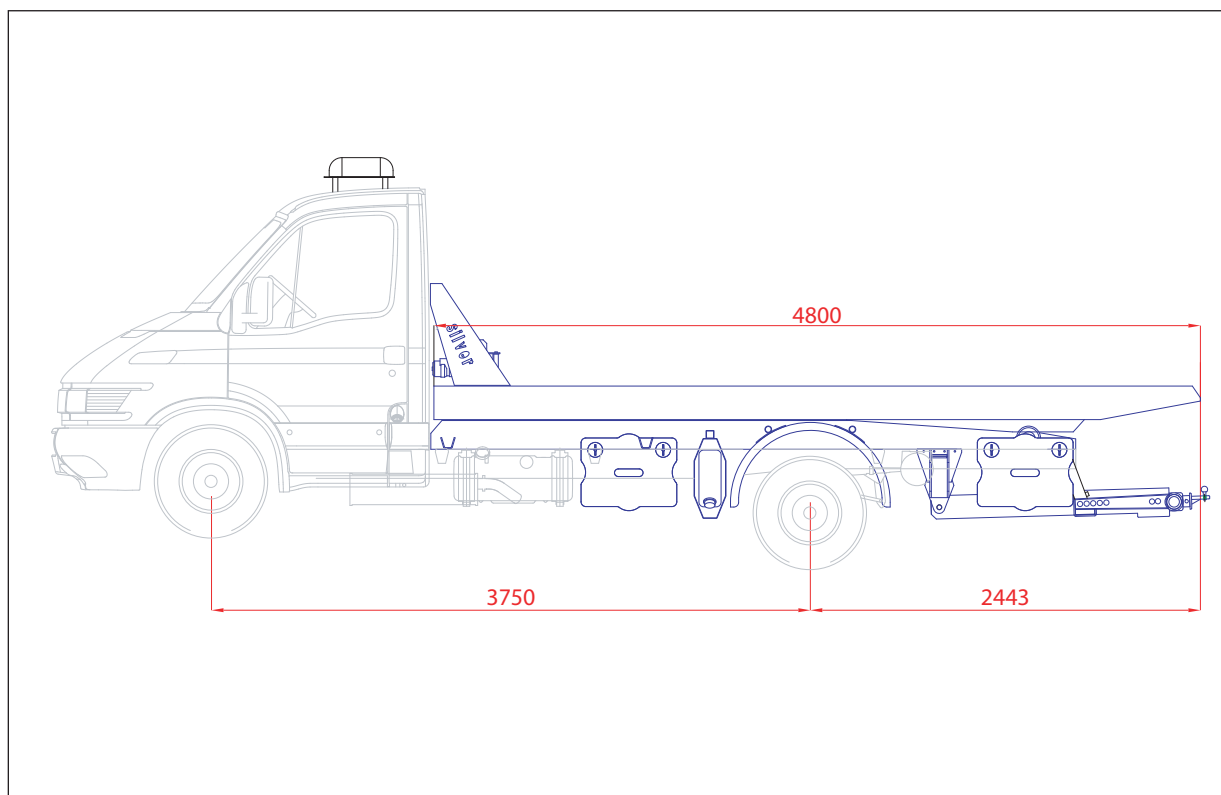

SOCCORSO STRADALE RECOVERY EQUIPMENT



DATI TECNICI

AUTOCARRO 5 - 6.5 ton.

| | |
|--|----------------------|
| Peso allestimento standard | Kg. 1400 |
| Peso totale autocarro | da Kg.5000 a Kg.6500 |
| Portata tecnica su forca tutta sfilata | Kg. 1200 |
| Portata tecnica del pianale | Kg. 3000 |

Dimensioni

| | |
|--|----------|
| Passo | 3750 mm. |
| A) Larghezza allestimento esterna | 2100 mm |
| B) Distanza filo telaio tra parte posteriore pianale e centro forca aperta | 1625 mm |

Caratteristiche generali

Pianale scarrabile con carrello stabilizzatore

- Incidenza di carico 11°
- Verricello con portate da 2,3 ton.
- Pianale autoportante
- Traslazione idraulica del verricello
- Movimentazioni idrauliche radiocomandabili pianale e verricello
- Pianale di carico con antiscivolo



TECHNICAL DATA

TRUCK 5 - 6.5 tonn.

| | |
|---|----------------------|
| Standard equipment weight | Kg. 1400 |
| Total weight | da Kg.5000 a Kg.6500 |
| Max lifting capacity with fork in extended position | Kg. 1200 |
| Technical loading surface | Kg. 3000 |

Dimensions

| | |
|---|----------|
| Wheelbase | 3750 mm. |
| A) External equipment width | 2100 mm |
| B) Distance between rear side of loading surface and middle part of fork in extended position | 1625 mm |

General characteristics

Slideback loading surface with stabilizer guide

- Access loading angle of 11°
- Winch: capacity of 2,3 ton.
- Self Carried platform
- Hydraulic traslation of the winch
- Remote control movements of the platform and of the winch
- Loading surface with anti-slip cover (on request)

Tutti i dati contenuti in questo stampato si intendono forniti a puro titolo indicativo e non impegnano in alcun modo la SILVER CAR S.r.l. che si riserva il diritto di apportare qualsiasi variazione ritenuta necessaria per esigenze tecniche e commerciali.
All data contained in this stamp are intended only as indicative information and does not commit in any way to SILVER CAR S.r.l. that reserves the right to make any change retained necessary because of commercial or technical reasons

